

T-VER-E50B2

Compact Power and Energy Meter

Quick Install Guide
ZZ05881-0D

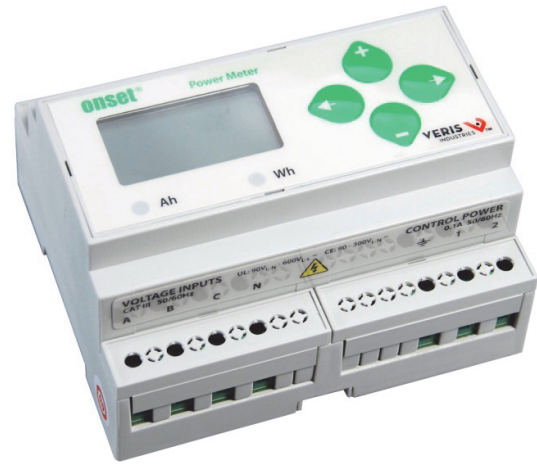

⚡ DANGER ⚡

HAZARD OF ELECTRIC SHOCK, EXPLOSION, OR ARC FLASH

- Follow safe electrical work practices. See NFPA 70E in the USA, or applicable local codes.
- This equipment must only be installed and serviced by qualified electrical personnel.
- Read, understand and follow the instructions before installing this product.
- Turn off all power supplying equipment before working on or inside the equipment.
- Any covers that may be displaced during the installation must be reinstalled before powering the unit.
- Use a properly rated voltage sensing device to confirm power is off. **DO NOT DEPEND ON THIS PRODUCT FOR VOLTAGE INDICATION**

Failure to follow these instructions will result in death or serious injury.

NOTICE

- This product is not intended for life or safety applications.
- Do not install this product in hazardous or classified locations.
- The installer is responsible for conformance to all applicable codes.
- Mount this product inside a suitable fire and electrical enclosure.

For use in a Pollution Degree 2 or better environment only. A Pollution Degree 2 environment must control conductive pollution and the possibility of condensation or high humidity. Consider the enclosure, the correct use of ventilation, thermal properties of the equipment, and the relationship with the environment. Installation category: CAT II or CAT III

Provide a disconnect device to disconnect the meter from the supply source. Place this device in close proximity to the equipment and within easy reach of the operator, and mark it as the disconnecting device. The disconnecting device shall meet the relevant requirements of IEC 60947-1 and IEC 60947-3 and shall be suitable for the application. In the US and Canada, disconnecting fuse holders can be used. Provide overcurrent protection and disconnecting device for supply conductors with approved current limiting devices suitable for protecting the wiring. If the equipment is used in a manner not specified by the manufacturer, the protection provided by the device may be impaired.

FCC PART 15 INFORMATION
Note: This equipment has been tested by the manufacturer and found to comply with the limits for a class B digital device, pursuant to part 15 of the FCC Rules. These limits are designed to provide reasonable protection against harmful interference when this equipment is operated in a residential environment. This equipment generates, uses, and can radiate radio frequency energy and, if not installed and used in accordance with the instruction manual, may cause harmful interference to radio communications. Operation of this equipment in a residential area may cause harmful interference in which case the user will be required to correct the interference at his own expense. Modifications to this product without the express authorization of Veris Industries nullify this statement.

This symbol indicates an electrical shock hazard exists. Documentation must be consulted where this symbol is used on this product.

Page 2

SPECIFICATIONS

Measurement Accuracy:		IEC 62053-22 Class 0.5S, ANSI C12.20 0.5%
Real Power and Energy		
Input Voltage Characteristics:		
Measured AC Voltage	Minimum 90V-LN (156V-L)	for stated accuracy
	UL Maximums: 600V _{L-L} (347V _{L-N})	
	CE Maximums: 300V _{L-N} (520V _{L-L})	
Impedance	2.5 MΩ (L-N)/5 MΩ (L-L)	
Frequency Range	45 to 65 Hz	
Input Current Characteristics:		
Measurement Input Range	0 to 0.333VAC or 0 to 1.0VAC (+20% over-range)	
Impedance	10.6kΩ (1/3 V mode) or 32.1kΩ (1 V mode)	
Control Power:		
AC	5VA max.; Minimum 90VAC,	
	UL Maximums: 600V _{L-L} (347V _{L-N}),	
	CE Maximums: 300V _{L-N} (520V _{L-L})	
DC*	3W max.; UL and CE: 125 to 300VDC	
Ride Through Time	100 msec at 120VAC	
Mechanical Characteristics:		
IP Degree of Protection (IEC 60529)	IP40 front display; IP20 Meter	
Terminal Block Screw Torque	0.37 ft-lb (0.5 N-m) nominal/0.44 ft-lb (0.6 N-m) max.	
Terminal Block Wire Size	26 to 14 AWG (0.13 to 2.08 mm ²)	
Rail	T35 (35mm) DIN Rail per EN50022	
Environmental Conditions:		
Operating Temperature	-30° to 70°C	
Storage Temperature	-40° to 85°C	
Humidity Range	<95% RH (non-condensing)	
Altitude of Operation	3 km max.	
Metering Category:		
North America	CAT III; for distribution systems up to 347 V L-N/600VAC L-L	
CE	CAT III; for distribution systems up to 300 V L-N	
Dielectric Withstand	Per UL 508, EN61010	
Conducted and Radiated Emissions	FCC part 15 Class B, EN55011/EN61000 Class B (residential and light industrial)	
Conducted and Radiated Immunity	EN61000 Class A (heavy industrial)	
Safety:		
North America (cULus)	UL508 (open type device)/CSA 22.2 No. 14-05	
Europe (CE)	EN61010-1:2001	

* External DC current limiting is required, see fuse recommendations.

Page 3

DIMENSIONS

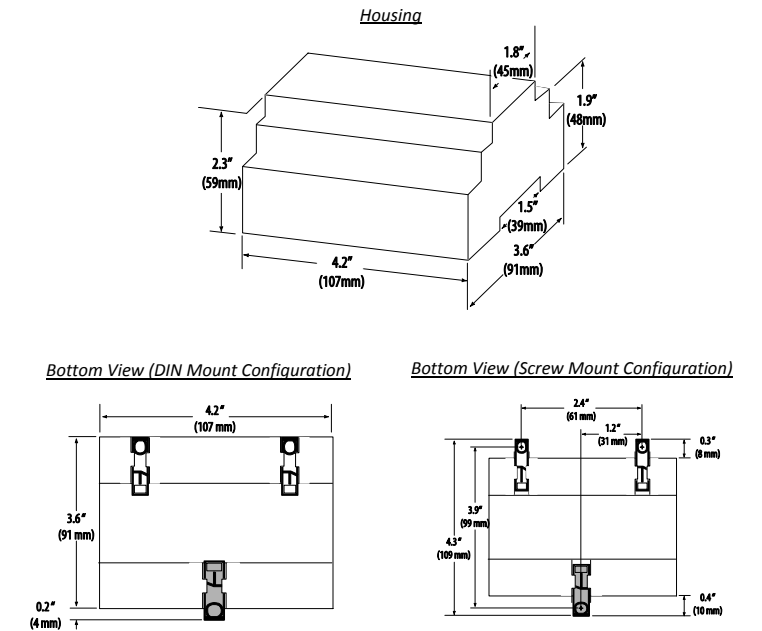

Page 4

Additional Resources:

For a copy of the full installation guide for this product, visit onsetcomp.com.



INSTALLATION

Disconnect power prior to installation.

Any covers that may be displaced during the installation must be reinstalled before powering the unit.

Mount the meter in an appropriate electrical enclosure near equipment to be monitored. Do not install on the load side of a Variable Frequency Drive (VFD).

The meter can be mounted in two ways: on standard 35 mm DIN rail or screw-mounted to the back of the enclosure.

A. DIN Rail Mounting

- Attach mounting clips to the underside of the housing by sliding them into the slots from the inside. The stopping pegs must face the housing, and the outside edge of the clip must be flush with the outside edge of the housing.
- Snap the clips onto the DIN rail. See diagram of the underside of the meter.
- To prevent horizontal shifting across the DIN rail, use two end stop clips.

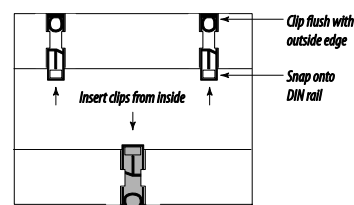

B. Screw Mounting

- Attach the mounting clips to the underside of the housing by sliding them into the slots from the outside. The stopping must face the housing, and the screw must be exposed on the outside of the housing.
- Use three #8 screws (not supplied) to the meter to the back of the enclosure. See diagram of the underside of the meter.

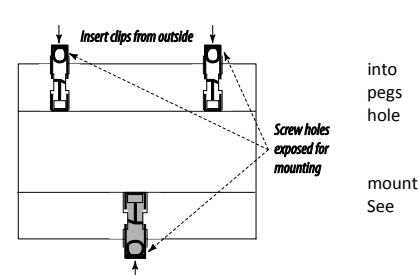

Page 5

SUPPORTED SYSTEM TYPES

The meter has a number of different possible system wiring configurations (see Wiring Diagrams, page 9-10). To configure the meter, set the System Type via the User Interface. The System Type tells the meter which of its current and voltage inputs are valid, which are to be ignored, and if neutral is connected. Setting the correct System Type prevents unwanted energy accumulation on unused inputs, selects the formula to calculate the Theoretical Maximum System Power, and determines which phase loss algorithm is to be used. The phase loss algorithm is configured as a percent of the Line-to-Line System Voltage (except when in System Type 1L + 1n) and also calculates the expected Line to Neutral voltages for system types that have Neutral (2L + 1N and 3L + 1n).

Values that are not valid in a particular System Type will display as "----" on the User Interface.

No. of wires	CTs		Voltage Connections			System Type	Phase Loss Measurements			Wiring Diagram Number
	Qty	ID	Qty	ID	Type		User Interface: SETUP>S SYS	VLL	VLN	
2	1	A	2	A, N	L-N	1L + 1n		AN		1
2	1	A	2	A, B	L-L	2L	AB			2
3	2	A, B	3	A, B, N	L-L with N	2L + 1n	AB	AN, BN	AN, BN	3
3	3	A, B, C	3	A, B, C	Delta	3L	AB, BC, CA		AB, BC, CA	4
4	3	A, B, C	4	A, B, C, N	Grounded Wye	3L + 1n	AB, BC, CA	AN, BN, CN	AN, BN, CN & AB, BC, CA	5, 6

Page 6

To avoid distortion, use parallel wires for control power and voltage inputs.

The following symbols are used in the wiring diagrams on the following pages.

Symbol	Description
	Voltage Disconnect Switch
	Fuse (installer is responsible for ensuring compliance with local requirements. No fuses are included with the meter.)
	Earth ground
	Current Transducer
	Potential Transformer
	Protection containing a voltage disconnect switch with a fuse or disconnect circuit breaker. The protection device must be rated for the available short-circuit current at the connection point.

CAUTION

RISK OF EQUIPMENT DAMAGE

- This product is designed only for use with 1V or 0.33V current transducers (CTs).
- DO NOT USE CURRENT OUTPUT (e.g. 5A) CTs ON THIS PRODUCT.
- Failure to follow these instructions can result in overheating and permanent equipment damage.

Page 7

PRODUCT DIAGRAM

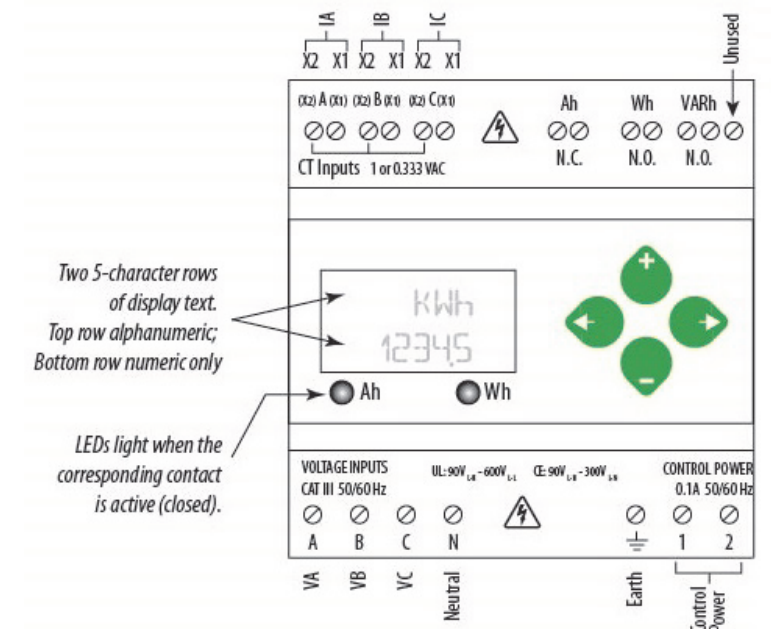

Page 8

WIRING DIAGRAMS

WARNING

RISK OF ELECTRIC SHOCK OR PERMANENT EQUIPMENT DAMAGE

CT negative terminals are referenced to the meter's neutral and may be at elevated voltages

- Do not contact meter terminals while the unit is connected
- Do not connect or short other circuits to the CT terminals

Failure to follow these instructions may cause injury, death or equipment damage.

CTs are not polarity sensitive. No need to observe orientation.

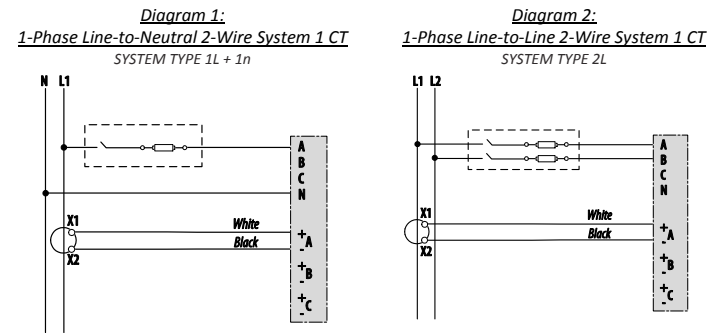

DISPLAY SCREEN DIAGRAM

LCD Screen:

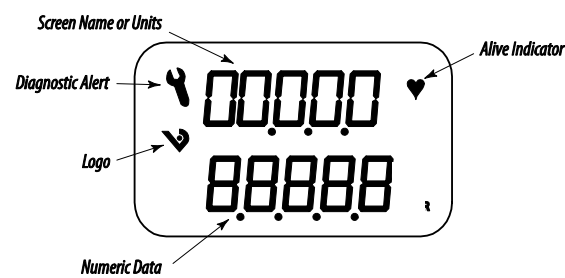

Buttons:

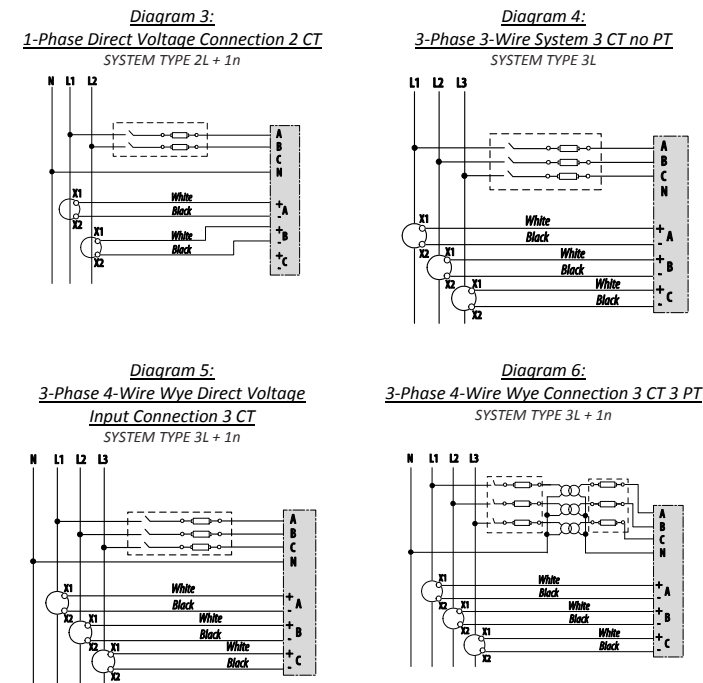
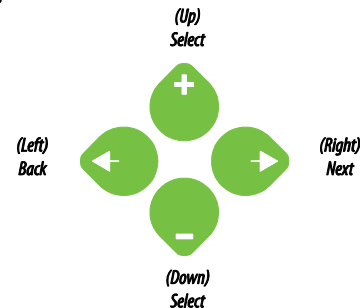

SETUP INSTRUCTIONS

These instructions assume the meter is set to factory defaults. If it has been previously configured, all optional values should be checked.

- Press **+** or **-** repeatedly until SETUP screen appears.
- >** to the PASWD screen.
- >** through the digits. Use **+** or **-** to select the password (the default is 00000). Exit the screen to the right.
- >** to the S CT (Set Current Transducer) screen.
 - >** to the CT V screen. Use **+** or **-** to select the voltage mode Current Transducer output voltage.
 - >** to the CT SZ screen and through the digits. Use **+** or **-** to select the CT size in amps.
 - >** back to the S CT screen.
- >** to the S SYS (Set System) screen.
 - >** to the SYSTM screen. Use **+** or **-** to select the System Type (see wiring diagrams on pages 9–10).
 - >** back to the S SYS screen.
- (Optional) **>** to the S PT (Set Potential Transformer) screen. If PTs are not used, then skip this step.
 - >** to the RATIO screen and through the digits. Use **+** or **-** to select the Potential Transformer step down ratio.
 - >** back to the S PT screen.

CONTROL POWER

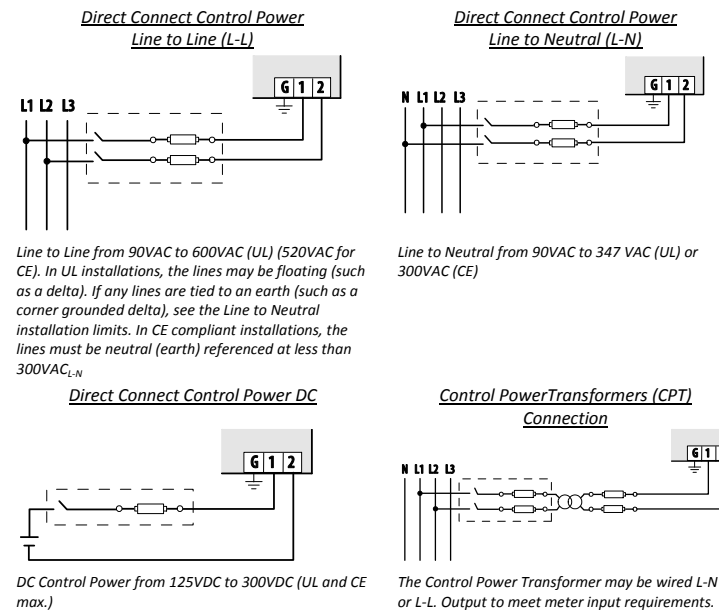

- Line to Line from 90VAC to 600VAC (UL) (520VAC for CE). In UL installations, the lines may be floating (such as a delta). If any lines are tied to an earth (such as a corner grounded delta), see the Line to Neutral installation limits. In CE compliant installations, the lines must be neutral (earth) referenced at less than 300VAC_{L-N}.
- Line to Neutral from 90VAC to 347 VAC (UL) or 300VAC (CE)
- DC Control Power from 125VDC to 300VDC (UL and CE max.)
- The Control Power Transformer may be wired L-N or L-L. Output to meet meter input requirements.
- Fuse Recommendations:**
- Keep the fuses close to the power source (obey local and national code requirements). For selecting fuses and circuit breakers, use the following criteria:
- Current interrupt capacity should be selected based on the installation category and fault current capability.
 - Over-current protection should be selected with a time delay.
 - The voltage rating should be sufficient for the input voltage applied.
 - Provide overcurrent protection and disconnecting means to protect the wiring. For DC installations, the installer must provide external circuit protection (suggested: 0.5 A time delay fuses).
 - The earth connection is required for electromagnetic compatibility (EMC) and is not a protective earth ground.

CONNECTING TO THE T-VER-E50B2

The T-VER-E50B2 has three outputs. These outputs can be connected to HOBO loggers as shown below.

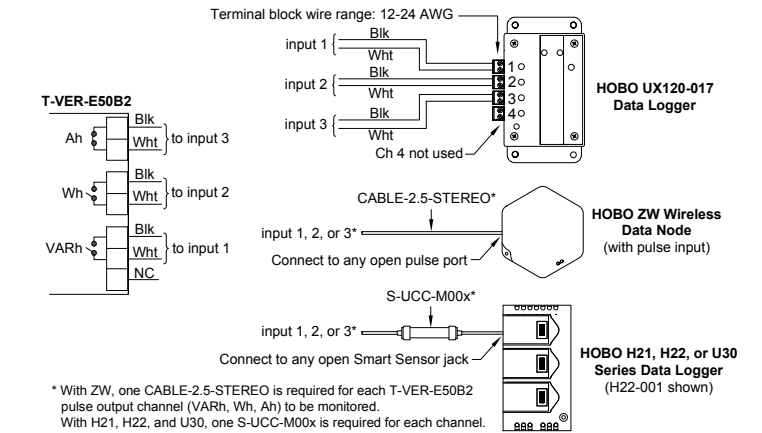

- Notes when connecting to non-HOBO® devices:**
- The T-VER-E50B2 has solid-state outputs rated for 30VAC/DC nom.
 - VARh and Wh are normally open; Ah is normally closed.
 - Maximum load current is 100mA at 25°C. Derate 0.56mA per °C above 25°C (e.g. 86mA@50°C).
 - The over-current protective device must be rated for the short circuit current at the connection point.
 - Pulse outputs are only intended to be connected to non-hazardous voltage circuits (SELV or Class 2). Do not connect to hazardous voltages.

CHINA ROHS COMPLIANCE INFORMATION (EFUP TABLE)

部件名称	产品中有毒有害物质或元素的名称及含量Substances					
	铅 (Pb)	汞 (Hg)	镉 (Cd)	六价铬 (Cr (VI))	多溴联苯 (PBB)	多溴二苯醚 (PBDE)
电子线路板	X	0	0	0	0	0
0 = 表示该有害物质在该部件所有均质材料中的含量均在 SJ/T11363-2006 标准规定的限量要求以下。 X = 表示该有害物质至少在该部件的某一均质材料中的含量超出SJ/T11363-2006标准规定的限量要求。						
Z000057-0A						

For technical support, contact Onset Computer at 1-800-LOGGERS (1-800-564-4377) or 508-759-9500, or via email at loggerhelp@onsetcomp.com.

© 2011–2013 Veris Industries and Onset Computer Corporation. Veris and the Veris “V” logo are trademarks or registered trademarks of Veris Industries, L.L.C. in the USA and/or other countries. Onset and HOBO are registered trademarks of Onset Computer Corporation.

14708-D MAN-VERIS-E50B2

For full setup instructions, see the T-VER-E50B2 Full Installation Guide available on onsetcomp.com.