

# Gastec Dosimeter Tubes



## Nextteq's Complete Line of Gas Detection Products (Over 600 Applications)

### Products include:

**Compressed Gas Monitoring\*  
Dosimeter Badges**

> **Gastec Dosimeter Tubes**

**Gastec Pump & Tube Systems**

**Piston Sampling Pumps &  
Detector Tubes**

**Polytec Tubes**

**Field Soil Test Kit**

**Pyrolyzer System & Tubes**

**Continuous Sampling Pump  
& Tubes**

**Injection Kits & Tubes**

## Simple, Pre-Calibrated, Direct-Read TWA Monitoring of Airborne Contaminants

Gastec Dosimeter Tubes provide users with a simple way to perform TWA (Time Weighted Average) monitoring of airborne contaminants. With Gastec's unique two-layer construction, you have a length-of-stain indication proportionate to the amount of gas contaminant present, ending with a distinct line of demarcation. The line of demarcation is read against a pre-calibrated measurement scale which is as easy to read as a thermometer and provides exposure levels in parts per million (PPM) hours.

To perform a sample, simply snap off the scored end of the dosimeter tube and insert it into the tube holder. For a TWA reading, wait until the end of the exposure period, then read the value on the scale that corresponds to the end of the stain length. Dividing this reading by the total length of time that the tube was exposed (expressed in hours) yields the average concentrations of the target contaminant for the period sampled.

Gastec Dosimeter Tubes are always ready to use and operate by direct diffusion exposure, so no cumbersome sampling pumps are needed. With no user calibration, extra equipment, laboratory analysis, lengthy calculations or extensive training required, Gastec Dosimeter Tubes reduce administrative and maintenance time and the possibility of user error.

\*uses Gastec Tubes

# Gastec Dosimeter Tubes

## Simple, Pre-Calibrated, Direct-Read TWA Monitoring of Airborne Contaminants

### VERSATILE AND ECONOMICAL SAMPLING SYSTEM

Gastec Dosimeter Tubes provide an inexpensive way to assess average gas concentrations. With the Gastec system, there is no need to make multiple worksite visits to change the sampling media. Gastec Dosimeter Tubes decrease your costs and risk of error by allowing you to accurately make repeated TWA measurements with the same dosimeter tube.

### VARIETY OF MEASURING RANGES PROVIDES GREATER FLEXIBILITY

Gastec provides users with three times more applications than competitive dosimeter tube systems. More applications with a variety of measuring ranges means Gastec tubes can cover all of your detection needs.

### ACCURATE AND RELIABLE RESULTS FOR PERSONNEL AND AREA MONITORING

Gastec Dosimeter Tubes are labeled with the application name and part number to provide easy selection and traceability. For guaranteed accuracy and reliability, Gastec calibration scales for dosimeter tubes are printed on each tube for each individual production lot. You avoid problems associated with accuracy or quality that are found with competitive systems that use a common calibration scale for different production lots.

With no ambiguous color comparison charts or wheels, users don't have to worry about errors resulting from inaccurate color matching. New tubes can be issued to each employee at the start of each shift with readings taken at the end of the shift to record an individual's daily exposure, contributing to a comprehensive worker's exposure history. Gastec Dosimeter Tubes are highly sensitive and selective to the targeted chemicals, as opposed to other non-specific testing methods. Dosimeter tubes can monitor TWA gas concentrations in a specific location or they can be worn on lapel clips to monitor an employee's exposure to potentially harmful gases over the course of the workday.

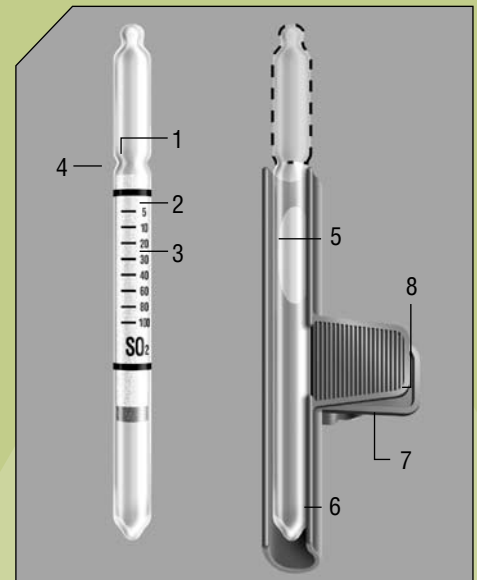

^ **Figure 1**

1. Diffusion Path
2. Indicating Layer
3. Calibration Marks
4. Easy Break End
5. Access Hole for Tube Removal
6. Tube Holder
7. Clip
8. String Attachment for Extra Precaution



^ **Figure 2**

To break the tube, the holder (with the tube inside) should be directed away from the body (e.g. toward the floor).



^ **Figure 3**

Note the end of the color change and record your reading. Then, simply divide by the number of hours for the TWA (PPM hours/hours worked).



### LONGER, MORE FLEXIBLE SAMPLING PERIODS

Gastec's unique passive diffusion process provides users with flexible sampling periods ranging from a half-hour to 48 hours, allowing very short exposures for capturing peak events and long exposures for accurate low concentration air quality measurements. The indication can be read and recorded at any time: during the work shift, at the end of the work shift, at the end of an overtime shift, or as late as 48 hours after activation for some tubes.

### COMFORTABLE, EASY-TO-WEAR, AND SAFE TUBE HOLDER

Each Gastec Dosimeter Tube is a rugged, precision instrument about the size of a fountain pen, able to snap securely into the lightweight tube holder. The tube holder is clipped easily to workers' clothing for true breathing zone measurements without the need for sampling pumps. The convenient and reusable tube holder (PN 710-) allows for safe tube end removal and secure sampling. Manufactured with a corrosion-resistant, high-impact plastic, this durable and rugged tube holder is designed to withstand the rigors of harsh workplace environments and is available in packs of 1, 3, or 10.

#### Why our System is Better:

Conventional diffusion tubes have a diffusional cross section area ( $A$ ) equal to the analyzer cross section area ( $A_0$ ).

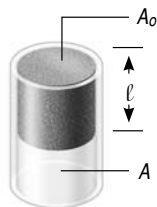

With Gastec's dual layer design, the diffusional cross section area ( $A$ ) is much larger than the analyzer cross section area ( $A_0$ ).

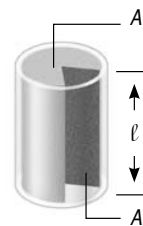

The length of the stain is determined by the equation  $l^2 = K \cdot \frac{A}{A_0} \cdot C \cdot T$ .

Where:  $l$  = Length of stain  
 $K$  = Tube reactivity constant  
 $A$  = Diffusional cross section area

$A_0$  = Analyzer cross section area  
 $C$  = Concentration  
 $T$  = Time

With conventional tubes, the ratio of  $A/A_0$  equals one. With Gastec tubes, the ratio of  $A/A_0$  is greater than one. With all other conditions constant, the  $l$  value will be larger for the Gastec tube, providing a longer stain per unit of concentration. Therefore, the Gastec tube has greater sensitivity and cleaner lines of demarcation.

# Gastec Dosimeter Tubes Specifications

Gas or Vapor to be Measured	CAS Number	Chemical Formula	2007 TLV-TWA (ACGIH)	Tube Number	Gastec Tube Name	Measuring Range (ppm)	Shelf Life (year)	Note	
								T	H
Acetaldehyde	75-07-0	CH <sub>3</sub> CHO	C 25	91D	Formaldehyde	0.1-20	1*		
				151D	Acetone	4-1200	2*	T	
				152D	Methyl ethyl ketone	1.2-360	2*	T	
Acetic acid	64-19-7	CH <sub>3</sub> CO <sub>2</sub> H	10	81D	Acetic acid	0.5-100	2	T	
Acetic anhydride	108-24-7	(CH <sub>3</sub> CO) <sub>2</sub> O	5	81D	Acetic acid	0.3-60	2	T	
Acetone	67-64-1	CH <sub>3</sub> COCH <sub>3</sub>	500	151D	Acetone	5-1500	2*	T	
				152D	Methyl ethyl ketone	1.4-420	2*	T	
Acetylene dichloride	540-59-0	ClCH:CHCl	200	132	Trichloroethylene	6-600	1*	T	
Ammonia	7664-41-7	NH <sub>3</sub>	25	3D	Ammonia	2.5-1000	2	T	
				3DL	Ammonia	0.1-10	2	T	H
Benzene	71-43-2	C <sub>6</sub> H <sub>6</sub>	0.5	122DL	Toluene	2.4-600	2	T	
1,3-Butadiene	106-99-0	CH <sub>2</sub> :CHCH:CH <sub>2</sub>	2	174D	1,3-Butadiene	1.3-200	2	T	
1,3-Butadiene, 2-methyl-	78-79-5	CH <sub>2</sub> :C(CH <sub>3</sub> ):CH:CH <sub>2</sub>	N/A	See Isoprene					
2-Butanone	78-93-3	CH <sub>3</sub> COC <sub>2</sub> H <sub>5</sub>	N/A	See Methyl ethyl ketone					
Carbon dioxide	78-79-5	CO <sub>2</sub>	5000	2D	Carbon dioxide	0.02-12%	2	T	
Carbon monoxide	630-08-0	CO	25	1D	Carbon monoxide	1.04-2000	2		
				1DL	Carbon monoxide	0.4-400	2*		
Chlorine	7782-50-5	Cl <sub>2</sub>	0.5	8D	Chlorine	0.08-100	2		
				132D	Trichloroethylene	2.4-240	1*	T	
Cumene	98-82-8	C <sub>6</sub> H <sub>5</sub> CH(CH <sub>3</sub> ) <sub>2</sub>	50	122DL	Toluene	3.4-850	2	T	
Dichlorvos	62-73-7	C <sub>4</sub> H <sub>7</sub> Cl <sub>2</sub> O <sub>4</sub> P	0.1 mg/m <sup>3</sup>	132D	Trichloroethylene	1-100			
trans-1,2-Dichloroethylene	156-60-5	ClCH:CHCl	200	174D	1,3-Butadiene	3.9-600	2	T	
				132D	Trichloroethylene	6-600	1*	T	
cis-1,2-Dichloroethylene	156-59-2	ClCH:CHCl	200	132D	Trichloroethylene	6-600	1*	T	
Dimethylamine	124-40-3	(CH <sub>3</sub> ) <sub>2</sub> NH	5	3D	Ammonia	1.9-750	2	T	
N,N-Dimethylethylamine	598-56-1	C <sub>2</sub> H <sub>5</sub> N(CH <sub>3</sub> ) <sub>2</sub>	N/A	3D	Ammonia	4-1600	2	T	
Ethanol	64-17-5	C <sub>2</sub> H <sub>5</sub> OH	1000	112D	Ethanol	100-25000	2		
Ethyl benzene	100-41-4	C <sub>6</sub> H <sub>5</sub> C <sub>2</sub> H <sub>5</sub>	100	122DL	Toluene	2.8-700	2	T	
Ethylene	74-85-1	CH <sub>2</sub> :CH <sub>2</sub>	200	174D	1,3-Butadiene	1.56-240	2	T	
Formaldehyde	50-00-0	HCHO	C 0.3	91D	Formaldehyde	0.1-20	1*		
Formic acid	64-18-6	HCO <sub>2</sub> H	5	81D	Acetic acid	0.55-110	2	T	
Furfural	98-01-1	Q(CH <sub>2</sub> ) <sub>2</sub> COH	2	91D	Formaldehyde	0.3-60	1*		
Hydrazine	302-01-2	N <sub>2</sub> H <sub>4</sub>	0.01	3D	Ammonia	1.6-650	2	T	
Hydrogen chloride	7647-01-0	HCl	C 2	14D	Hydrogen chloride	1-100	2	T	H
				132D	Trichloroethylene	1.8-180	1*	T	
				17D	Hydrogen fluoride	0.4-40	2	T	H
Hydrogen cyanide	74-90-8	HCN	C 4.7	12D	Hydrogen cyanide	1-200	2		H
Hydrogen fluoride	7664-39-3	HF	0.5	17D	Hydrogen fluoride	1-100	2	T	H
				14D	Hydrogen chloride	2.5-250	2	T	H
Hydrogen peroxide	7722-84-1	H <sub>2</sub> O <sub>2</sub>	1	32D	Hydrogen peroxide	0.5-40	2	T	
Hydrogen sulfide	7783-06-4	H <sub>2</sub> S	10	4D	Hydrogen sulfide	0.2-200	2		
Isoprene	78-79-5	CH <sub>2</sub> :C(CH <sub>3</sub> ):CH:CH <sub>2</sub>	N/A	174D	1,3-Butadiene	2.6-400	2	T	
Isopropyl benzene	98-82-8	C <sub>6</sub> H <sub>5</sub> CH(CH <sub>3</sub> ) <sub>2</sub>	N/A	See Cumene					
Methylamine	74-89-5	CH <sub>3</sub> NH <sub>2</sub>	5	3DL	Ammonia	0.19-19	2	T	H
Methyl ethyl ketone (MEK)	78-93-3	CH <sub>3</sub> COC <sub>2</sub> H <sub>5</sub>	200	152D	Methyl ethyl ketone	2-600	2*	T	
				91D	Formaldehyde	0.125-25	1*		
				151D	Acetone	6.5-1950	2*	T	
Methyl isobutyl ketone	108-100-1	(CH <sub>3</sub> ) <sub>2</sub> CHCH <sub>2</sub> COCH <sub>3</sub>	50	151D	Acetone	11.5-3450	2*	T	
				152D	Methyl ethyl ketone	4-1200	2*	T	
Nitric acid	7697-37-2	HNO <sub>3</sub>	2	14D	Hydrogen chloride	0.8-80	2	T	
				17D	Hydrogen fluoride	0.32-32	2	T	H
Nitrogen dioxide	1012-44-0	NO <sub>2</sub>	3	9D	Nitrogen dioxide	0.1-30	1*	T	
				9DL	Nitrogen dioxide	0.01-3	1*		
Perchloroethylene	127-18-4	Cl <sub>2</sub> C:CCl <sub>2</sub>	25	See Tetrachloroethylene					
Styrene	100-42-5	C <sub>6</sub> H <sub>5</sub> CH:CH <sub>2</sub>	20	122DL	Toluene	26-6500	2	T	
				174D	1,3-Butadiene	48-7600	2		
Sulfur dioxide	7446-09-5	SO <sub>2</sub>	2	5DH	Sulfur dioxide	10-600	2	T	
				5D	Sulfur dioxide	0.2-100	2		
Tetrachloroethylene	127-18-4	Cl <sub>2</sub> C:CCl <sub>2</sub>	25	133D	Tetrachloroethylene	3-150	1*	T	
				132D	Trichloroethylene	1.5-150	1*	T	
Toluene	108-88-3	C <sub>6</sub> H <sub>5</sub> CH <sub>3</sub>	20	122DL	Toluene	2-500	2	T	
Trichloroethylene	79-01-6	Cl <sub>2</sub> C:CHCl	10	132D	Trichloroethylene	3-300	1*	T	
Triethylamine	121-44-8	(C <sub>2</sub> H <sub>5</sub> ) <sub>3</sub> N	1	3D	Ammonia	5.3-2100	2	T	
Trimethylamine	75-50-3	(CH <sub>3</sub> ) <sub>3</sub> N	5	3DL	Ammonia	0.23-23	2	T	
Vinyl chloride	75-01-4	CH <sub>2</sub> :CHCl	1	174D	1,3-Butadiene	1.56-240	2	T	
Xylene	1330-20-7	C <sub>6</sub> H <sub>4</sub> (CH <sub>3</sub> ) <sub>2</sub>	100	122DL	Toluene	3.4-850	2	T	

**Key:** CAS = Chemical abstracts service; C = Ceiling value; H = Humidity correction required; ppm = Parts per million; \* = Store in refrigerator; T = Temperature correction required; TLV-TWA = Threshold limit value - time weighted average; Shaded = Correction factor/chart



**For more information: NEXTTEQ LLC**  
 8406 Benjamin Rd. • Suite J • Tampa, FL 33634 USA • Tel: 813-249-5888 • Toll-free Tel: 877-312-2333  
 Fax: 813-249-0188 • Toll-free Fax: 877-312-2444 • Email: info@nextteq.com • www.nextteq.com

Gastec tubes and pumps are manufactured by the Gastec Corporation. Nextteq is Gastec's exclusive U.S. master wholesale distributor.

©2006 Nextteq LLC. All rights reserved. Nextteq is a registered trademark of Nextteq LLC. Gastec is a registered trademark of Gastec Corporation. All other brand names and trademarks mentioned in this document are the properties of their respective holders. All features, specifications, and prices are subject to change without notice. P/N 530601 Rev C 04/08